

Yngri

KLASSISK GÅBIL I METALL
CLASSIC LEARNING CAR IN METAL



SE / NO / ENG

Everyday products for young explorers.
Designed by Scandinavians.



SE VIKTIGT Spar manualen för framtida bruk.

SE

IVARNING

Viktig! Följer man inte dessa varningar och monteringsanvisningar så kan det leda till allvarlig skada eller olycka.

- **"VARNING:LÄMNA ALDRIG BARNET UTAN UPPSIKT."**
- **"VARNING:Ej lämplig för barn under 3 år pga. smådelar som kan utgöra kvävningsrisk.**
- **"VARNING:Denna leksak ska enbart monteras av vuxna."**
- **"VARNING:Denna produkt ska alltid övervakas av en vuxen då barnet använder den."**
- **"VARNING: Detta fordon är tillverkad för endast ett barns användande."**
- **"VARNING: Denna produkt är tillverkad för barn över 2 år gammal och med en maxvikt på 25 kg."**
- **"VARNING: RISKI Håll barnet inom säkra ytor. Håll dig borta från alla typer av vatten (t.ex. pool, sjö, etc.) för att förhindra drunkning. Använd inte på sluttningar, vägar, nära motorvägar, nära bilar, trappor, branta sluttningar och gränder."**
- **ANVÄNDNING AV FORDONET** med ett barn som väger mer än 25 kilogram kommer orsaka xtra slitage på fordonet.
- Sitt alltid på sadeln då produkten används.
- Använd alltid skor eller andra lämpligt plagg.
- Oppbevar plastemballasje utenfor barns rekkevide for å forhindre kvelningsfare.

VÅRD OCH UNDERHÅLL:

Rengöring och underhåll av denna produkt skall utföras regelbundet av användaren. Rengöring och underhåll av vagnen får endast utföras av en vuxen.

RENGÖRING:

Torka kontinuerligt av alla metalldel med en mjuk fuktig trasa.

Undvik starka kemikaliska rengöringsmedel.

Rengör alltid produkt med en torr trasa samt torka av vagnen efter vistats ute i regn för att förhindra eventuell rost.

UNDERHÅLL:

Kontrollera kontinuerligt hjulen och alla rörliga delar på denna produkt.

Använd produkten på plan mark för att skydda hjulen och dess konstruktion.

Håll bilen borta från solen för att förhindra att metall rosta.

Dette produktet oppfyller kravene i henhold til EN 71-1: 2014+A1:2018, EN 71-2:2011+A1:2014 & EN71-3:2013



max 25 kg

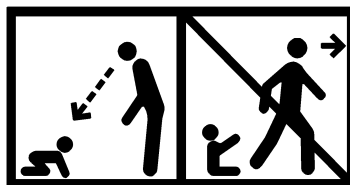

FÖR KONTAKT

E-mail: customerservice@yngri.no

Designed in Scandinavia – Made in China for BARNAS HUS NORGE AS
Grenseveien 107 A, 0663 Oslo, NORWAY



DELAR



1. Ratt x 1

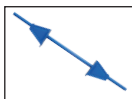

2. Bakaxel x 1

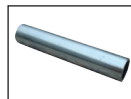

3. Säte x 1

4. Styrstångsrör
x 1

5. Framaxel x 1

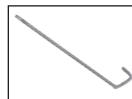

6. Styrstång x 1



7. Plastbrick x 2



8. Hjul x 4



9. Mtallbricka x 4



10. Skruv x 8



11. Motorhuv x 1

12. Bakaxel
bustning x 2

13. Tryckbricka x 1



14. Tanklock x 1



15. Låsmutter x 8



16. Navkapsel x 4



17. Ändmutter x 1

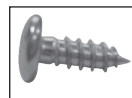

18. Låsskruv x 3

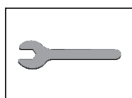
19. Navkapsel
verktyg x 1

20. Skiftnyckel-A x 1



20. Skiftnyckel-B x 1

MONTERINGSANVISNING

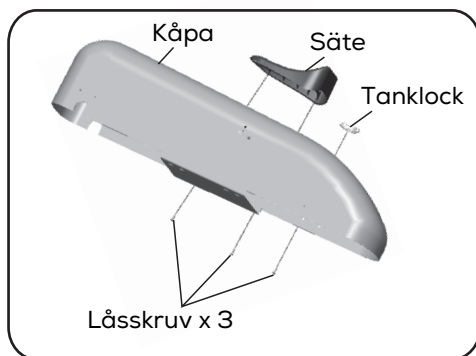

1. Säte & Tanklocks montering

- Fäst sätet (#3) på toppen av motorhuv (11) enligt bilden.
- Sätt in låsskruv (#18) i hålen för sätet.
- Fäst tanklocket (#14) på baksidan av motorhuv.
- Sätt in låsskruvar (#18) i skruvhålen, dra åt skruven med en skruvmejsel.

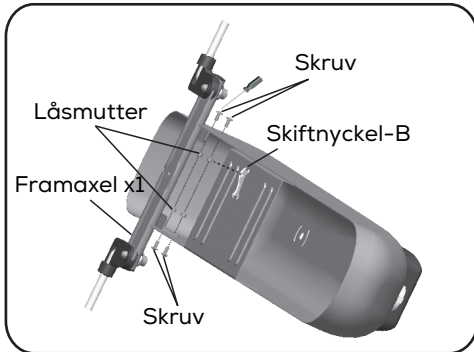

2. Framaxel montering

- Fäst framaxeln (#5) på motorhuvens framsida och placera den som bilden visar.
- Sätt i skruv (#10) & låsmutter (#15)
Dra åt skruvarna och muttrarna med en skruvmejsel och skiftnyckel-B (#21).

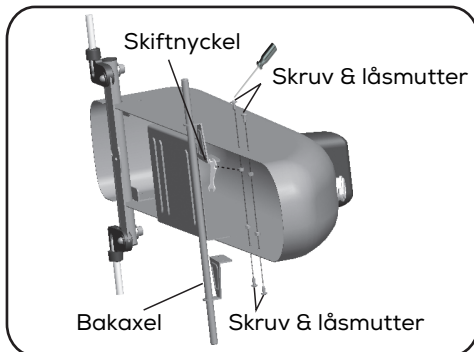

3. Bakaxel montering

- Fäst den bakre axeln (#2) på baksidan av motorhuv och rikta in den som bilden visar.
- Sätt i skruv (#10) & låsmutter (#15)
- Dra åt skruvarna och muttrarna med skruvmejsel och skiftnyckel-B (#21).

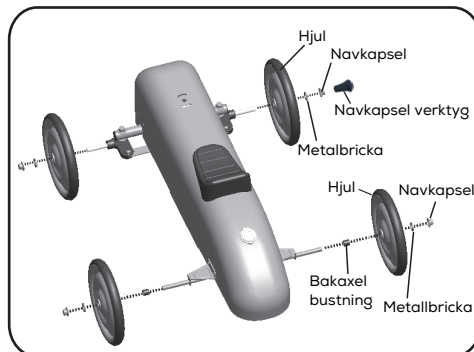

4. Hjulmontering

- Fäst framhjulet (#8) på framhjulsaxeln, sätt in bricka (#10) och navkapsel (#16).
- Dra åt navkapseln med navkapselverktyget (#19).
- Fäst bakhjulsbustningen (#12) och bakhjulen (#8) på bakhjulsaxeln, sätt på bricka (#10) och navkapsel (#18), dra sedan åt navkapseln med hammare och navkapselverktyget (#19)

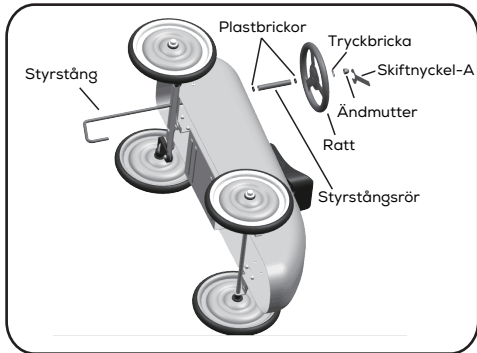

5. Ratt montering

- För in styrstången (#6) genom motorhuvnen underifrån.
- Trä på 2 st plastbrickor (#7) styrröret (#4) enligt bilden.
- Fäst sedan ratten (#1) och tryckbrickan (#15) och ändmutter (#17).
- Dra åt muttern med skiftnyckel-A (#20).

NO VIKTIG – LES INSTRUKSJONENE NØYE FØR PRODUKTET TAS I BRUK, OG TA VARE PÅ DEM FOR FREMTIDIG REFERANSE.

NO

ADVARSLER:

Hvis disse instruksjonene og monteringsanvisningen ikke følges kan det føre til alvorlige skader og mulig død.

- "ADVARSEL: ALDRI ETTERLAT BARNET UTEN TILSYN."
- "ADVARSEL: Egner seg ikke for barn under 3 år pga. smådeler og kvelningsfare."
- "ADVARSEL: Dette leketøy må bli satt sammen av bare voksne."
- "ADVARSEL: Det skal alltid være en voksen til stede når dette produktet er i bruk."
- "ADVARSEL: Denne kjøretøy er produsert for barn over 2 år gammel og med en maksvekt på 25 kg."
- "ADVARSEL: Dette kjøretøyet er beregnet for maksimalt en barn gangen."
- "ADVARSEL: BRUKSFARE! Hold barnet innenfor trygge områder. Hold god avstand til alle typer vann (eksempelvis svømmebasseng, innsjø, strand... osv) for å forhindre drukning, Skal ikke brukes i bakker og helninger, offentlig vei, i nærheten av motorvei, i nærheten av biler, trapper, kanter og portrom."
- BRUK AV KJØRETØYET med et barn som veier mer enn 25 kilo, vil føre til ekstra slitasje på kjøretøyet.
- Sitt alltid på setet.
- Bruk alltid sko eller annet egnet fottøy.
- Oppbevar plastemballasje utenfor barns rekkevide for å forhindre kvelningsfare.

STELL OG VEDLIKEHOLD:

Rengjøring og vedlikehold av dette produktet skal utføres regelmessig.
Rengjøring og vedlikehold skal utføres av en voksen.

RENGJØRING:

Tørk rutinemessig av metalldel med en myk fuktig klut.
Unngå sterke alkaliske rengjøringsmidler.

Tørk alltid av metalldeler hvis produktet har vært i kontakt med vann for å unngå rustdannelse.

VEDLIKEHOLD:

Sjekk rutinemessig tilstanden på hjul og andre bevegelige deler.
Bruk produktet på flat overflate for å unngå skade på hjulene.
Hold produktet unna solskinn for å unngå at metall eldes av sollys.

Dette produktet oppfyller kravene i henhold til EN 71-1: 2014+A1:2018, EN 71-2:2011+A1:2014 & EN71-3:2013



max 25 kg

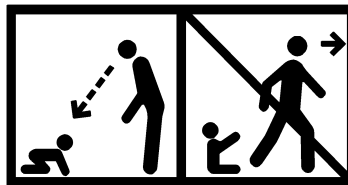

FORBRUKERKONTAKT

E-mail: customerservice@yngri.no

Designed in Scandinavia – Made in China for BARNAS HUS NORGE AS

Grenseveien 107 A, 0663 Oslo, NORWAY

DELER



1. Ratt x 1

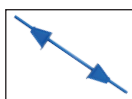

2. Bakaksel x 1



3. Sete x 1

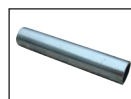

4. Gjennomføringsrør x 1



5. Foraksel x 1

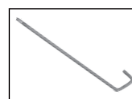

6. Styrestag x 1



7. Plastskive x 2



8. Hjul x 4



9. Skive x 4



10. Skruer x 8



11. Panser x 1

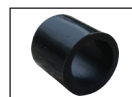

12. Bakakselhylse x 2



13. Trykkskive x 1



14. Tanklokk x 1



15. Mutter x 8



16. Navkapsel x 4



17. Rattmutter x 1

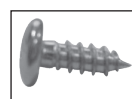

18. Gjenge-skruer x 3



19. Navkapselverktøy x 1

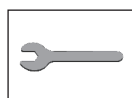

20. Fastnøkkel-A x 1



20. Fastnøkkel-B x 1

MONTERINGSANVISNING

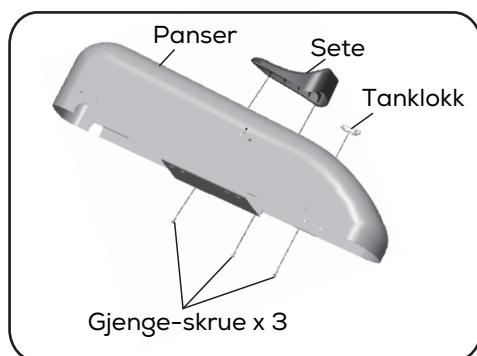

1. Sete og tanklokk montering

- Fest setet (#3) til toppen av panseret som vist på bildet.
- Stikk inn gjenge-skruene (#18) i skruhellene på panseret.
- Fest tanklokket (#14) bak på panseret.
- Skru inn gjengeskruene (#18) i skruhellene på setet og stram til med et skrujern.

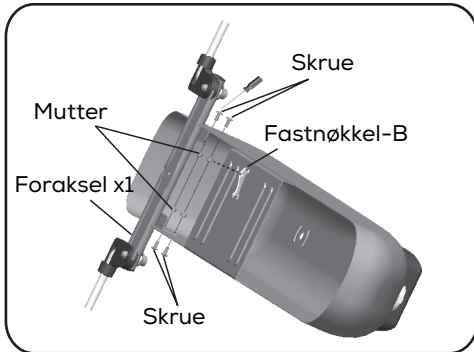

2. Montering av foraksel

- Fest forakselen (#5) til fronten av panseret som vist på bildet.
- Skru inn Skruene (#10) og mutterne (#15) og stram disse med et skrujern og fastnøkkel B (#21)

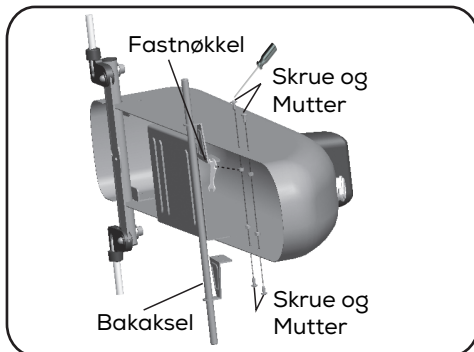

3. Montering av bakaksel

- Fest bakakselen (#2) til bakkdelen av panseret som vist på bildet.
- Skru inn Skruene (#10) og mutterne (#15) og stram disse med et skrujern og fastnøkkel B (#21)

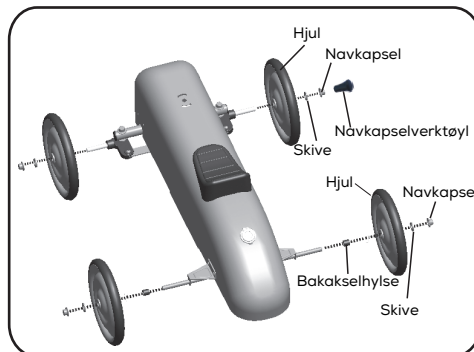

4. Hjulmontering

- Fest forhjulene (#8) til forakselen, sett på skive (#9) og navkapsel (#16).
- Fest navkapselen med navkapselverktøyet (#19).
- Fest bakhjulene (#8) og bakakselhylsene (#12) til bakakselen, sett på skive (#9) og navkapsel (#16) og stram til med hammer og navkapselverktøyet (#19).

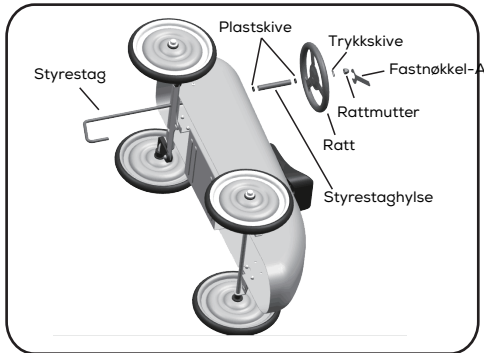

5. Montering av ratt

- Stikk styrestaget (#6) gjennom panseret fra undersiden.
- Monter på plastskivene (#7), styrestaghylsen (#4) og de 2 plastskivene (#7) som vist på bildet.
- Monter deretter på rattet (#1), trykkskiven (#15) og rattmutteren (#17).
- Stram rattmutteren med Fastnøkkel A (#20).



ENG IMPORTANT Keep this instructions for future reference.

ENG

!WARNINGS

Failure to follow these warnings and the assembly instructions could result in serious injury or death.

- "WARNING: NEVER LEAVE CHILD UNATTENDED."
- "WARNING: Not suitable for children under 3 years due to small parts – Choking hazard."
- "WARNING: This toy is required to be assembled by adults only."
- "WARNING: Adult Supervision is required while child is play with this product."
- "WARNING: This product is intended for children over 2 years old and weighing up to 25 kg."
- "WARNING: The vehicles shall be used only for up one child."
- "WARNING: RIDING HAZARD! Keep Children Within Safe Riding Areas. Keep away from any kind of water (e.g. swimming pool, lake...etc.) to prevent drownings. Do not use on slope, roads, near highway, near cars, steps, steep inclines, and alleys."
- USE OF THE VEHICLE with a child weighing more than 25 kg will cause excessive wear and stress on the product.
- Always sit on the seat paddle.
- Always wear shoes or suitable footwear.
- Keep plastic covering away from children to avoid suffocation.

CARE AND MAINTENANCE :

The cleaning and maintenance of this product must be carried out on a regular basis by the user. The cleaning and maintenance of the car must only be carried out by an adult.

CLEANING:

Routinely wipe clean the product with a soft damp cloth. Avoid strong alkali and strong alkaline detergent. Always dry the metal parts to prevent the formation of rust if the car come into contact with water.

MAINTENANCE :

Routinely check the condition of the wheels and all moving part. Use the car on flat ground to protect the wheels. Keep the car away from sun to prevent metal rusting.

This product complies with EN 71-1: 2014+A1:2018, EN 71-2:2011+A1:2014 & EN71-3:2013



max 25 kg

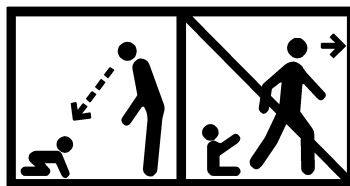

FOR CONTACT

E-mail: customerservice@yngri.no
 Designed in Scandinavia – Made in China for BARNAS HUS NORGE AS
 Grenseveien 107 A, 0663 Oslo, NORWAY



PART



1. Steering Wheel x 1

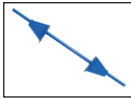

2. Rear Axle x 1



3. Seat x 1

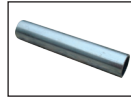

4. Steering Shaft Loop x 1

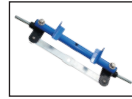

5. Front Axle x 1

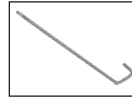

6. Steering shaft x 1



7. Plastic Washer x 2



8. Wheel x 4



9. Washer x 4



10. Screw x 8



11. Bonnet x 1

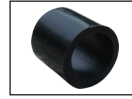

12. Back Axle Loop x 2



13. Thrust Washer x 1



14. Tank Cap x 1



15. Hex Nut x 8



16. Hub Cap x 4



17. Dome Head Nut x 1

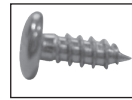

18. Self-Tapping Screw x 3



19. Hub Cap Tool x 1

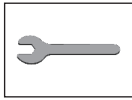

20. Wrench-A x 1

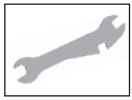

20. Wrench-B x 1

ASSEMBLY INSTRUCTION

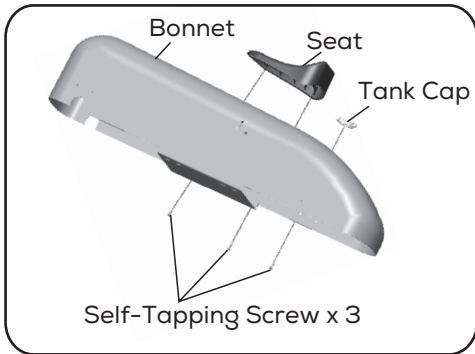

1. Seat & Tank Cap Assembly

- Attach the Seat (#3) to the top of the Bonnet (#11) as shown.
- Insert Self-Tapping Screw (#18) into the seat screw hole.
- Attach the Tank Cap (#14) to the back of the Bonnet.
- Insert Self-Tapping Screws (#18) into the screw hole, tighten the screw with screwdriver.

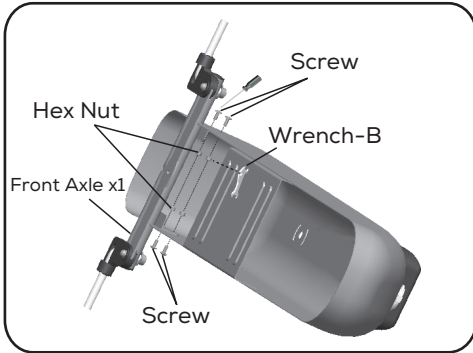

2. Front Axle Assembly

- Attach the Front Axle (#5) to the front of bonnet and line up as shown.
- Insert Screw (#10) & Hex Nut (#15)
- Tighten the screws & nuts with screwdriver and Wrench-B (#21).

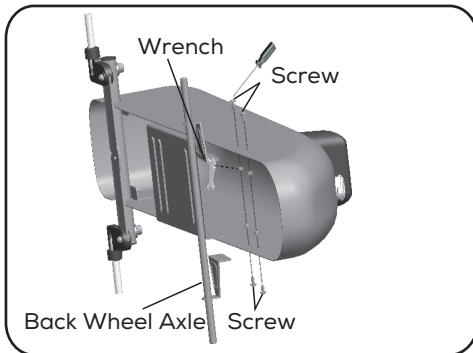

3. Rear Axle Assembly

- Attach the Rear Axle (#2) to the rear of bonnet and line up as shown.
- Insert Screw (#10) & Hex Nut (#15)
- Tighten the screws & nuts with screwdriver and Wrench (#21).

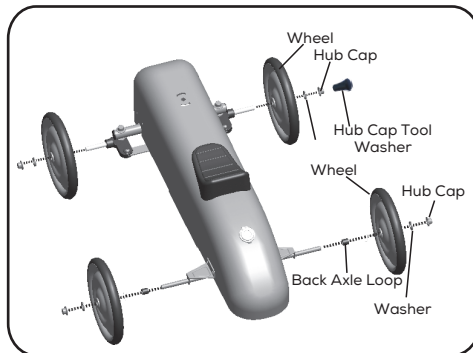

4. Wheel Assembly

- Attach the Front Wheel (#8) to the front wheel axle, insert Washer (#10) and Hub Cap (#16).
- Tighten the hub cap with the Hub Cap Tool (#19).
- Attach the Back Wheel Axle Loop (#12) & the Rear Wheels (#8) to the rear wheel axle, insert Washer (#10) and Hub Cap (#18), then install the hub cap with hammer and hub cap tool (#19)

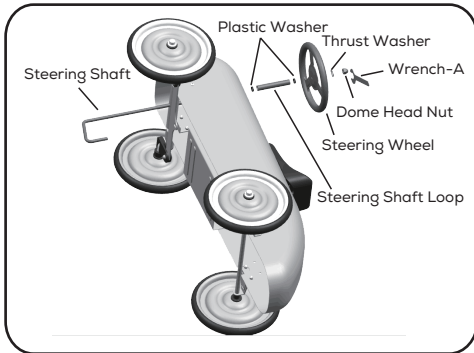

5. Steering Wheel Assembly

- Insert the Steering Shaft (#6) through the bonnet from underneath.
- Insert on top the Plastic Washer (#7) Steering Shaft Loop (#4) and 2pcs of Plastic Washer (#7) as shown.
- Then attach the Steering Wheel (#1) and Thrust Washer (#15) and the Dome Head Nut (#17).
- Tighten the nut with Wrench-A (#20).



Yngri

DESIGNED BY SCANDINAVIANS

Made in China

BARNAS HUS NORGE AS
Grenseveien 107 A, 0663 Oslo, NORWAY
customerservice@yngri.no
www.yngri.no

